

## CNC Yatay İşleme "T" Kanallı Tabla

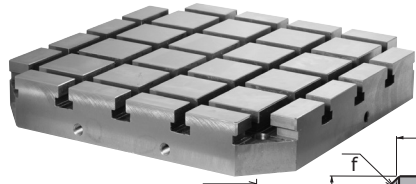

"T" Kanallı CNC Yatay İşleme Tablası Standart Bağlama Elemanlarına Uyumludur.

**Malzeme;** GG 26 DIN Normalize Edilmiştir. "T" Kanal; 14-18 DIN 650 Standartlarındadır.

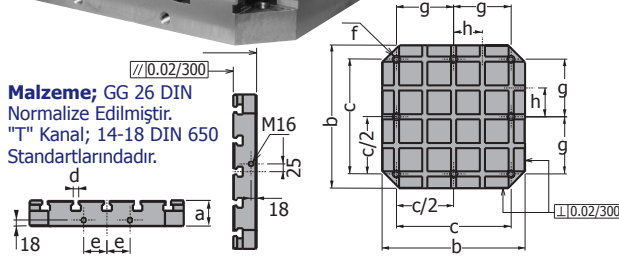

Sipariş 2490	a	b	c	d	e	f	±0.02	±0.02	Ağırlık kg.
7540014	400	320		55			160	80	87
7550014	500	400	14	75			200	100	120
7563014	630	500		100			250	125	197
7540018	400	320		55	18		160	80	85
7550018	500	400	18	75			200	100	118
7563018	630	500		100			250	125	195

## CNC Dik İşleme Delikli Tabla



Tabla Yüzeyindeki M12 - M16 Bağlantı Dişlerin Merkez Aralığı 50 mm ± 0.02'dir. İsteğe Göre Çelik Burçlar Sertleştirilir

Standart Bağlama Ekipmanlarına Uyumludur.

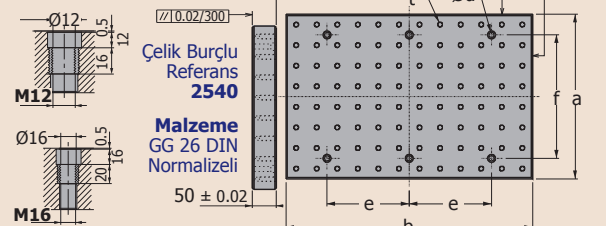

Sipariş 2530	a	b	Ød	t	kg.	Sipariş 2530	a	b	Ød	t	kg.
040012	400	600			90	040016	400	600			87
050012	500	600			112	050016	500	600			108
060012	600	800	18	M12	162	060016	600	800	18	M16	155
140012	400	800			119	140016	400	800			115
145012	450	900			151	145016	450	900			146
150012	500	1000			173	150016	500	1000			171

## CNC Yatay / Dik İşleme Delikli Gönye

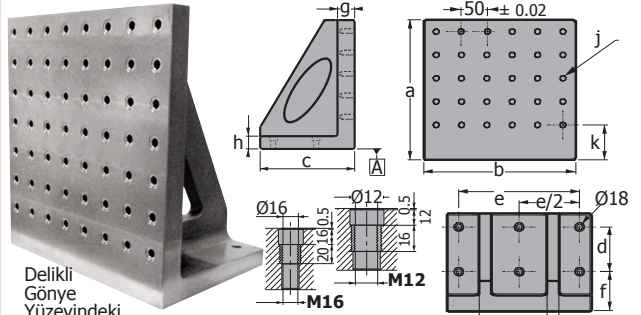

Delikli Gönye Yüzeyindeki M12 - M16 Diş Merkez Aralığı 50 ± 0.02'dir.

Sipariş 2570	a	b	c	d	e	f	g	h	j	k	s	s1	kg	
30012	300	220	100	250	90	40	30				75	25	170	50
40012	400	280	160	320	90	40	30		M 12		75	30	240	88
50012	500	345	200	400	90	50	35				75	35	300	175
63012	630	435	250	500	100	50	40				105	40	360	298
30016	300	220	100	250	90	40	30				75	25	170	45
40016	400	280	160	320	90	40	30		M 16		75	30	240	84
50016	500	345	200	400	90	50	35				75	35	300	170
63016	630	435	250	500	100	50	40				105	40	360	293

## CNC Yatay İşleme Delikli Tabla



Tabla Yüzeyindeki M12 - M16 Bağlantı Dişlerin Merkez Aralığı 50 mm ± 0.02'dir.

İsteğe Göre Çelik Burç Dişleri Sertleştirilmiş Teslim Edilir. Standart Bağlama Ekipmanlarına Uyumludur.

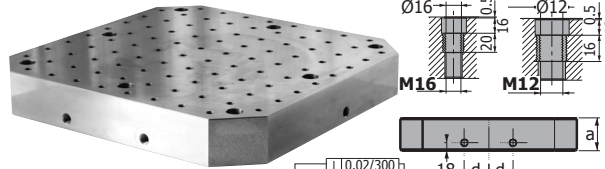
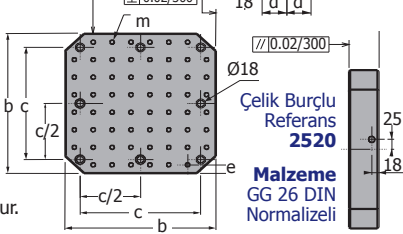

Sipariş 2510	a	b	c	d	e	m	Ağırlık kg.
7540012	400	320	55	25			97
7550012	500	400	75	25		M 12	124
7563012	630	500	100	40			201
7540016	400	320	55	25			95
7550016	500	400	75	25		M 16	122
7563016	630	500	100	40			199

## CNC Dik İşleme "T" Kanallı Pleyt

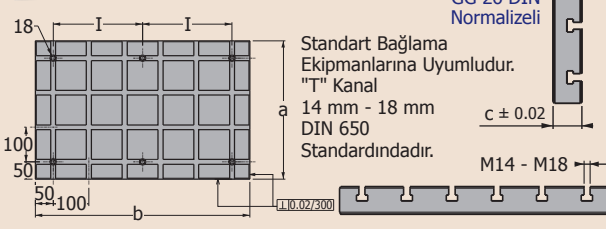
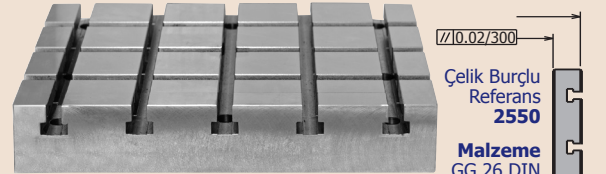

Sipariş 2550	a	b	c	kg.	Sipariş 2550	a	b	c	kg.
040014	400	600		90	040018	400	600		114
050014	500	600		115	050018	500	600		148
060014	600	800	60 mm	198	060018	600	800	75 mm	240
140014	400	800		120	140018	400	800		158
145014	450	900		162	145018	450	900		205
150014	500	1000		199	150018	500	1000		258

## CNC Yatay / Dik "T" Kanallı Gönye

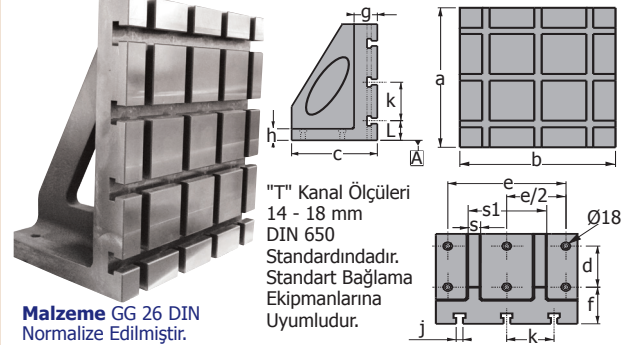

**Malzeme** GG 26 DIN Normalize Edilmiştir.

Sipariş 2590	a	b	c	d	e	f	g	h	j	k	L	s	s1	kg	
30014	300	220	100	250	90	60	30				100	50	25	170	50
40014	400	300	160	320	90	60	30		M 14		100	50	30	240	100
50014	500	350	200	400	90	60	35				100	50	35	300	185
63014	630	450	250	500	100	65	40				125	65	40	360	315
30018	300	220	100	250	90	60	30				100	50	25	170	50
40018	400	300	160	320	90	60	30		M 18		100	50	30	240	98
50018	500	350	200	400	90	60	35				100	50	35	300	174
63018	630	450	250	500	100	65	40				125	65	40	360	286